

**MODEL "251CDA / 254CDA" CHAIN DRIVEN ZERO PRESSURE PALLET ACCUMULATOR
ASSEMBLY AND OPERATING INSTRUCTIONS**

RECEIVING INSTRUCTIONS

- 1) Prior to uncrating the equipment, check the number of crates, boxes, skids, etc. received against the freight bill to insure that all items shipped are on the job site.
- 2) Check to see that none of the equipment was damaged in transit. If damages occurred, note damages on freight bill and immediately contact the motor carrier and file claim for the damages.
- 3) Transport conveyors on their skids as near the installation site as possible.

INSTALLATION INSTRUCTIONS – MECHANICAL

- 1) Remove conveyor sections from their skids and place upside down on floor in proper sequence based on the match mark identification on the conveyor sections and direction of product flow. (See Figure "0" for clarification).

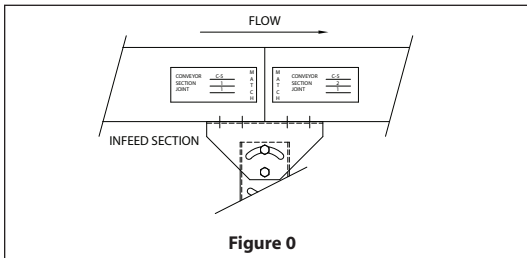

Figure 0

- 2) Beginning with the first section in match mark sequence, bolt a support at each end, leaving a space for the second bed section on pivot plate. Remember to set stands at proper elevation while second section is inverted. (See Figure "1" for support positions). Finger tighten bolts only and turn section over (right side up) and place into position.
- 3) Take the next intermediate section in the match mark sequence and add one stand to far end, bolting on 1/2 of pivot plate. Finger tighten stand bolts, turn right side up and attach end without stand to previous section. Repeat this procedure until complete conveyor is assembled.

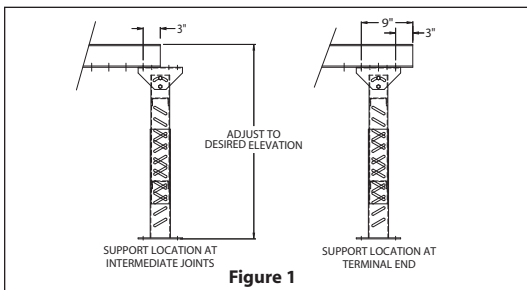

Figure 1

- 4) Do not wrench tighten bolts until unit is assembled, aligned, and lagged to the floor.
- 5) Remove front guard from each conveyor section to expose zone to zone RC60 drive chain. (See Figure "2"). Check sprocket alignment with straight edge prior to installing drive chain. Install RC60 chain from section to section on double sprockets and fasten with connecting link. Make sure chain rides over UHMW wear bar as shown in Figure "2".

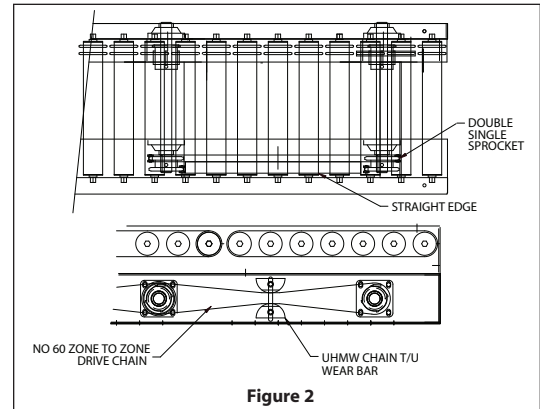

Figure 2

- 6) RC60 zone to zone drive chains have been properly tensioned at factory. If chain should need adjustment, the UHMW plastic wear bar may be raised by loosening its bolts and sliding it up in the vertical slot. **DO NOT OVER TIGHTEN CHAINS. TIGHT CHAINS CAN CAUSE PREMATURE WEAR OF DRIVE COMPONENTS OR DAMAGE TO OTHER PARTS.** (See Figure "3" for proper chain tension).

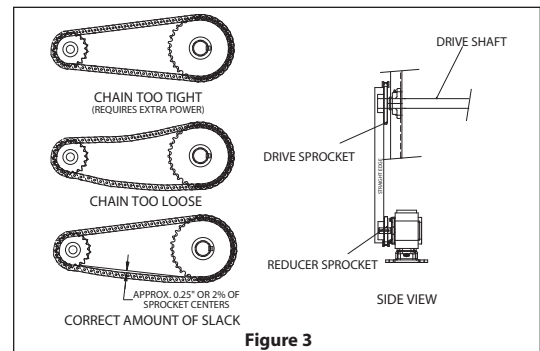

Figure 3

- 7) Replace chain guards after chains are installed and ensure chains have been checked for proper tension.
- 8) Align Conveyor - To align conveyor, tie a chalk line to the exact center of the pulleys at each end of the conveyor and pull it tight. Take each section of the conveyor starting at one end and align the frames so that the chalk line is in the exact center of each section of the conveyor.
- 9) Place level across width of conveyor to make sure conveyor is level.
- 10) Install lag bolts (not furnished) through holes in support feet.
- 11) Recheck alignment and wrench tighten all bolts.
- 12) Recheck alignment.
- 13) All sensor rollers are wired in the "DOWN" position for shipment. Prior to running conveyor, remove these wires so sensor rollers will move to the "UP" or operating position. **DO NOT RUN CONVEYOR BEFORE REMOVING WIRES.**

INSTALLATION INSTRUCTIONS – ELECTRICAL

- 1) Connect power to the motor in accordance with the name plate on the electrical motor. Electrical controls for starting and stopping the conveyor are not supplied as part of the conveyor equipment. Contact a qualified electrician to recommend and install suitable electrical controls for this function.
- 2) **IMPORTANT:** Prior to turning conveyor on but after power has been connected to motor, remove chain guard from reducer to conveyor drive shaft. Remove drive chain. Turn power on to run motor/reducer. Determine rotation direction of reducer output shaft. Rotation direction must be in same direction as intended product flow on conveyor. If it is not the same, electrician must change the electric motor lead connections to achieve proper rotation. Before re-installing chain guard, check sprocket alignment with straight edge and proper chain tension. (See figure "3" on previous page). Re-install chain guard.
- 3) The speed reducer is shipped from the factory with oil. However, remove upper most filler plug to insure reducer is oiled properly. If not, fill with oil in accordance with manufacturer's instructions sent with reducer. The reducer may have a loose breather plug attached. If so, you must install breather plug in the reducer in accordance with the installation instructions furnished with the speed reducer to prevent oil seal failure.
- 3) Zone #1 (discharge zone) is equipped with an electric solenoid and limit switch (supplied as part of conveyor). The logic to control these switches is not supplied as a standard part of the conveyor. However, a suggested manually operated electrical system to control these components is shown on wiring diagram per figure "4". Note that push button, motor starter, control relay, and latch control relay shown in diagram are not supplied by ACSI. Contact a qualified electrician for supplying and making power connections to these switches.

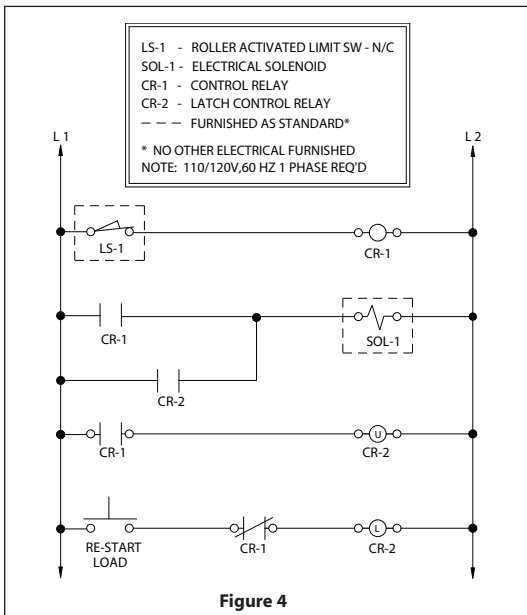

Figure 4

SENSOR ARM ZONE CONNECTIONS

- 1) All "251CDA" accumulation zones are set-up and adjusted at factory prior to shipment. In order to ship the conveyor, it is necessary to disconnect the sensor arm control rods. Before the conveyor is disassembled for shipment, the sensor arm control linkage rods are "matched marked" by the factory so that the exact adjustment position can be located at the time of installation. (See figure "5").
- 2) Match up white match marks on rods with ends of opposing sensor arm linkage control rods and securely tighten nuts on U-bolt clamps. Be sure the sensor arm linkage arm rods are in the "factory set" position before any field adjustments are attempted.

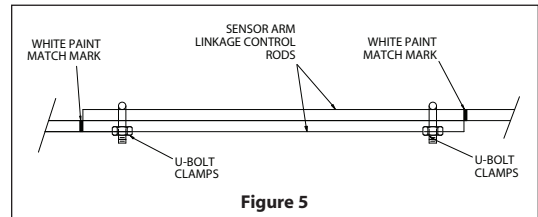

Figure 5

ZERO PRESSURE ADJUSTMENT

Each accumulation zone is equipped with a "sensor roller" which, when the product depresses it, activates the accumulation feature. For the accumulation feature to work, it is important for the sensor rollers to be adjusted properly. These sensor rollers have been factory set, however, it may be necessary to make field adjustments from time to time.

NOTE: DO NOT MAKE ANY ADJUSTMENTS UNTIL A TEST RUN OF THE CONVEYOR HAS BEEN MADE AND ADJUSTMENTS ARE DEEMED NECESSARY.

ZONE#1 - ELECTRIC SOLENOID AND LIMIT SWITCH ADJUSTMENT PROCEDURE.

- 1) Zone #1 (discharge zone) is equipped with a roller operated limit switch and an electric solenoid which operates a mechanical clutch. Both a 120VAC operated. When power is applied to the solenoid, the mechanical clutch is engaged and the discharge zone is powered. When the first load passes over sensor roller #1, the sensor roller arm depresses limit switch (LS #1). This must deactivate the solenoid, which in turn disengages the clutch allowing the load in Zone #1 to accumulate.
- 2) To adjust the electric solenoid, first apply 120VAC power to its terminals in accordance with wiring diagram (See Figure "6"). With sensor roller #1 in the raised position (See Figure "7"), if actuator bar "C" does not clear clutch dog "D" by 1/4" with power on, loosen solenoid mounting bolts and adjust solenoid assembly until 1/4" clearance is obtained. Re-tighten bolts.

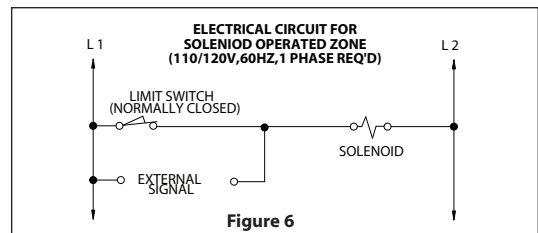

Figure 6

- 3) To adjust limit switch (LS #1), loosen set screw on limit switch activator arm (See Figure "7"), and rotate arm so that as sensor roller is depressed, limit switch will be activated. Retighten set screw. Activation should occur when sensor roller is approximately 1/4" above tread rollers. A slight "click" can be heard when the limit switch is activated.
- 4) Zone #1 is the only accumulation zone supplied with electrical components as standard equipment as shown in Figure "7". As an option, other zones may be supplied to operate electrically.

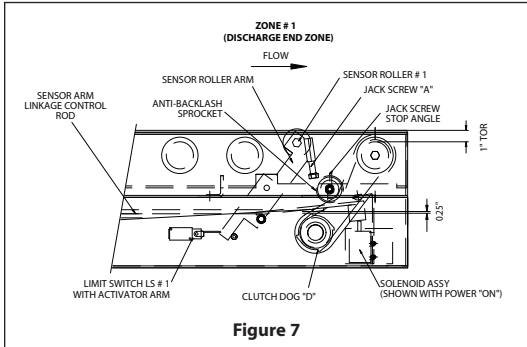

Figure 7

MECHANICAL ZERO PRESSURE ADJUSTMENTS (See Figure "8")

- 1) With jack-screw "A" adjust sensor roller lower travel limit from 0" to 1/8" below top of tread rollers with sensor rollers depressed fully. (Jack-screw firmly against stop angle). Tighten jam nuts.
- 2) With sensor roller #1 and #2 in the up position, raised, adjust sensor arm linkage rod "E" (loosen nuts on U-bolt clamp and adjust length as necessary) until actuator bar "C" clears clutch dog "D" 3/16".
- 3) With sensor roller #1 depressed fully and sensor roller #2 in the up position, adjust locking collar on sensor rod "B" until actuator bar "C" clears clutch dog "D" 3/16".
- 4) With sensor roller #1 and sensor roller #2 fully depressed, actuator bar "C" should engage clutch #2.
- 5) Repeat steps #1 through #4 for all other mechanical zones.

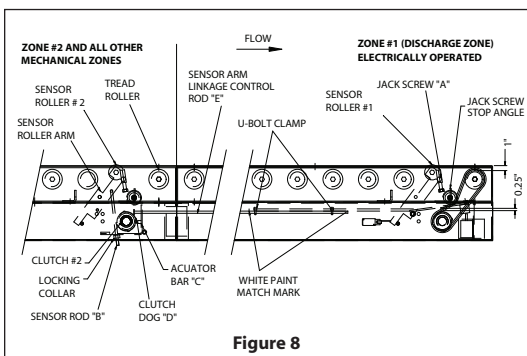

Figure 8

SAFETY INFORMATION

- 1) After completion of conveyor installation and **BEFORE** operation, personnel operating the conveyor must be properly trained in its use. It is recommended these employees be walked through the proper sequence of starting and stopping the motor drive, shown where hazardous areas exist along the length of the conveyor (identified by safety labels attached to the conveyor frame and drive guards) and correct loading and unloading methods. Make sure safety labels are legible and that personnel understand their meaning.
- 2) Conveyor should **NEVER** be operated with any of the safety guards removed as physical harm could come to the user. All pinch points of the conveyor are guarded and also identified by safety labels attached in the guarded pinch point area. Instruct users to turn the conveyor off and notify the proper personnel should a guard be missing and the conveyor is running.
- 3) Only qualified maintenance personnel should perform work on the conveyor. Should the unit require maintenance, **disconnect conveyor motor drive from power source before attempting to adjust or repair conveyor.** If guards were removed to perform the maintenance task, they must be replaced before attempting to operate conveyor. If guards are damaged and become unusable they must be replaced. Locate the conveyor's serial number plate, which is mounted near the motor drive, and contact your ACSI distributor for a replacement. He will need the serial number of the conveyor to secure the correct guard.

SEQUENCE OF OPERATION

LOADING THE CONVEYOR (See Figure "9")

- 1) When a load is placed on the infeed end of the conveyor it will continue to travel the length of the conveyor until it reaches the last (discharge) zone of the conveyor (Zone #1). At this time the load will depress sensor roller #1 which disengages the clutch in Zone #1 allowing the load to accumulate (stop).
- 2) As soon as sensor roller #1 is depressed, it sends a mechanical signal to Zone #2 indicating Zone #1 is occupied.
- 2) When load #2 depresses sensor roller #2, the clutch in Zone #2 is disengaged allowing load #2 to accumulate. At the same time, a mechanical signal is sent to Zone #3 indicating Zone #2 is occupied. This sequence of events will continue until the conveyor is fully loaded.

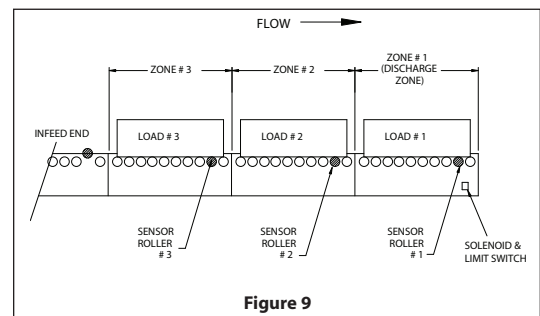
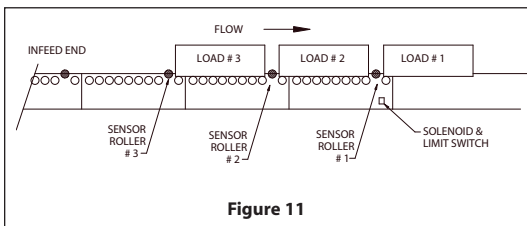
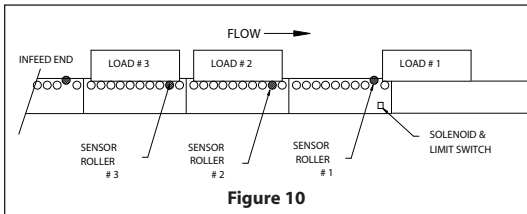

Figure 9

UNLOADING THE CONVEYOR (See Figure "10" & "11")

- 1) To activate Zone #1 to release load #1, an electrical signal (120VAC or 24VDC) must be sent to the solenoid switch controlling the clutch in Zone #1. (This external signal IS NOT SUPPLIED as part of the conveyor equipment).
- 2) When the electrical signal is received by the solenoid switch controlling the clutch in Zone #1, load #1 will be discharged from the conveyor (Figure "10").
- 3) As soon as load #1 clears sensor roller "1", load #2 will advance to Zone #1 and stop when it depresses sensor roller #1 (Figure "11"). The 120VAC signal must again be sent to the solenoid controlling the clutch to discharge load #2.
- 4) As soon as load #2 clears sensor roller "2", load "3" will advance to Zone #2 and stop on sensor roller "2". (Figure "11").
- 5) This sequence continues automatically as long as the loads in Zone #1 are removed, creating an opening for the loads to advance.
- 6) Electric & mechanical time delays are available as optional items for fork truck unloading.

NOTE: The above sequence of operation covers the standard operating procedures of the "22ACDE." For other options that are available for special applications or requirements contact factory.



PREVENTATIVE MAINTENANCE

(See Lubrication and Maintenance Check List for more details.)

- 1) **DRIVE CHAINS** - Every 500 hours - Wipe off grease with solvent and apply clean SAE 20 motor oil. Check tension on main drive chain (1/4" - 2% (of sprocket centers) movement midway between sprockets). Use straight edge and check sprocket alignment.
- 2) **ELECTRIC MOTOR** - Every 1000 hours - Remove grease plugs (if supplied on motor) and grease motor bearings sparingly with ball bearing grease.
- 3) **SPEED REDUCER** - Every 750 hours - Remove filler and drain plugs. Flush and refill with lubricant suggested by reducer manufacturer.

- 4) **TREAD ROLLERS** - Every 500 Hours - Make sure all rollers turn freely. Replace any that are dented, warped, binding, etc.
- 5) **FLANGE MOUNTED BEARINGS (PULLEYS)** - Every 1000 hours - Grease pulley bearings through grease fittings using grease gun. CAUTION: Do not over grease.
- 6) **ENTIRE CONVEYOR** - Daily, weekly. - Look for any abnormal action of conveyor, oil leaks, unusual noises, etc. Repair at once.

- PARTS LIST - 251CDA / 254CDA

- | | |
|---|-----------------------------------|
| ① ELECTRIC MOTOR | ①⑦ LIMIT SWITCH |
| ② GEAR REDUCER | ①⑧ SENSOR ROLLER ASS'Y |
| ③ REDUCER SPROCKET | ①⑨ TREAD ROLLER |
| ④ MAIN DRIVE CHAIN GUARD | ②⑩ #40 CHAIN - ROLL TO ROLL |
| ⑤ MOTOR BASE | ②① SOLENOID |
| ⑥ CONVEYOR DRIVEN SPROCKET | ②② SOLENOID ACTUATOR BAR ASS'Y |
| ⑦ ZONE DRIVE SPROCKET #13-077 | ②③ #60 CHAIN - ZONE TO ZONE |
| ⑧ SUPPORT ASS'Y WITH KNEEBRACE | ②④ MAIN DRIVE SHAFT |
| ⑨ 4 BOLT FLANGE BEARING #12-025 | ②⑤ ZONE DRIVE SHAFT |
| ⑩ CLUTCH #19-129 RIGHT HAND W/ SPROCKET #13-083 | ②⑥ CLUTCH MOUNTING CHANNEL |
| CLUTCH #19-130 LEFT HAND W/ SPROCKET #13-083 | ②⑦ MOUNTING CHANNEL |
| ①① LINKAGE CONTROL ROD | ②⑧ ZONE TO ZONE CHAIN GUARD |
| ①② U-BOLT CLAMP | ②⑨ CONVEYOR FRAME ASS'Y |
| ①③ SENSOR ROD ASS'Y | ③⑩ CHAIN GUARD |
| ①④ MECHANICAL ACTUATOR BAR ASS'Y | ③① J-BOX #19-058 W/ COVER #19-059 |
| ①⑤ SPLICE PLATE | ③② SENSOR ROLLER STOP ASS'Y |
| ①⑥ UHMW PLASTIC WEAR BAR ASS'Y | ③③ MAIN DRIVE CHAIN |

