

**MODEL "190RB / 190RBI / 190RBWS" CONVEYOR
ASSEMBLY AND OPERATING INSTRUCTIONS**

RECEIVING INSTRUCTIONS

- 1) Prior to uncrating the equipment, check the number of crates, boxes, skids, etc. received against the freight bill to insure that all items shipped are on the job site.
- 2) Check to see that none of the equipment was damaged in transit. If damages occurred, note damages on freight bill and immediately contact the motor carrier and file claim for the damages.
- 3) Transport conveyors on their skids as near the installation site as possible.

INSTALLATION INSTRUCTIONS – MECHANICAL

- 1) Remove conveyor sections from their skids and place upside down on floor in proper sequence based on the match mark identification on the conveyor sections.

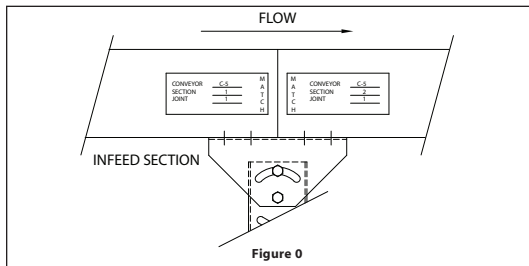

- 2) Beginning with the first section in match mark sequence, bolt a support at each end, leaving a space for the second bed section on pivot plate. Remember to set stands at proper elevation while section is inverted. (See Figure "1" for support positions). Finger tighten bolts only and turn section over (right side up) and place into position.
- 3) Take the next intermediate section in the match mark sequence and add one stand to far end, bolting on 1/2 of pivot plate. Finger tighten stand bolts, turn right side up and attach end without stand to previous section. Repeat this procedure until complete conveyor is assembled.

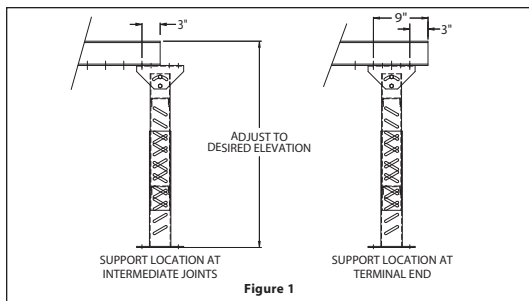

- 4) Do not wrench tighten bolts until unit is assembled, aligned, and lagged to the floor.
- 5) Align Conveyor - To align conveyor, tie a chalk line to the exact center of the pulleys at each end of the conveyor and pull it tight. Take each section of the conveyor starting at one end and align the frames so that the chalk line is in the exact center

of each section of the conveyor.

- 6) Turnbuckle assemblies (x-bracing) are provided to square conveyor frame sections. These assemblies are shipped loose and are to be installed on every other frame following drive section. Measure diagonally across frame section, corner to corner, to check frame for squareness. If necessary, adjust turnbuckles until conveyor frame is square.
- 7) Place level across width of conveyor to make sure conveyor is level.
- 8) Install lag bolts (not furnished) through the holes in support feet
- 9) Recheck alignment and wrench tighten all bolts.
- 10) Recheck alignment.

CONVEYOR BELTING INSTALLATION

- 1) Belting has been cut to length and laced at factory.
- 2) Install belting around pulleys and over snub and return rollers. If end drive and end take-up, make sure take-up pulley adjustment has pulley all the way in towards bed section. Insert lacing pin provided with belt to connect the two ends.
- 3) Tension belt by adjusting bolts at terminal tail pulley or belt take-up pulley in center drive. CAUTION: Equal adjustment of both screws is necessary for proper belt tracking.
- 4) The belt should be tight enough to prevent belt slippage at drive pulley when conveyor is loaded.
- 5) Because there is initial belt stretch during the first few weeks of conveyor use, careful attention should be given to proper belt tightness during break in. Also, high humidity can cause belt tightness and low humidity can cause belt stretch. Check belt tightness after severe changes in humidity.
- 6) Never apply any type of chemical to belt for aiding grip at drive pulley. This procedure could cause severe damage to conveyor drive components or belting.

SAFETY INFORMATION

- 1) After completion of conveyor installation and **BEFORE** operation, personnel operating the conveyor must be properly trained in its use. It is recommended these employees be walked through the proper sequence of starting and stopping the motor drive, shown where hazardous areas exist along the length of the conveyor (identified by safety labels attached to the conveyor frame and drive guards) and correct loading and unloading methods. Make sure safety labels are legible and that personnel understand their meaning.

- 2) Conveyor should **NEVER** be operated with any of the safety guards removed as physical harm could come to the user. All pinch points of the conveyor are guarded and also identified by safety labels attached in the guarded pinch point area. Instruct users to turn the conveyor off and notify the proper personnel should a guard be missing and the conveyor is running.
- 2) Only qualified maintenance personnel should perform work on the conveyor. Should the unit require maintenance, **disconnect conveyor motor drive from power source before attempting to adjust or repair conveyor.** If guards were removed to perform the maintenance task, they **must be replaced** before attempting to operate conveyor. If guards are damaged and become unusable they must be replaced. Locate the conveyor's serial number plate, which is mounted near the motor drive, and contact your ACSI distributor for a replacement. He will need the serial number of the conveyor to secure the correct guard.

OPERATING INSTRUCTIONS

- 1) Before the electric motor is turned on, check the following items:
 - A) Make sure correct voltage is connected to motor in accordance with motor name plate.
 - B) The speed reducer is shipped from the factory with oil. However, remove upper most filler plug to insure reducer is oiled properly. If not, fill with oil in accordance with manufacturer's instructions sent with reducer. The reducer may have a loose breather plug attached. If so, you must install breather plug in the reducer in accordance with the installation instructions furnished with the speed reducer to prevent oil seal failure.
 - C) Remove chain guard at motor and reducer. Check sprocket alignment with straight edge and proper chain (or driver belt) tension. (See Figure "2" below.)

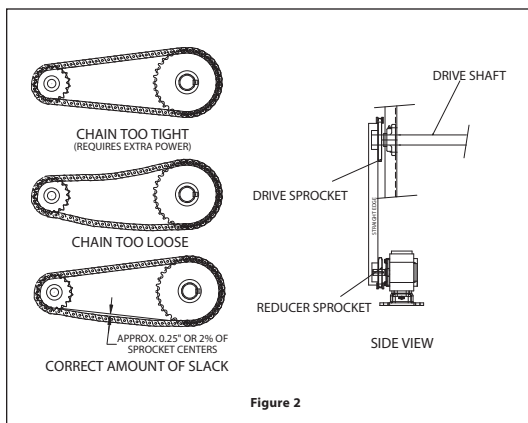

- D) Install carrying (tread) rollers in slots in frame.

- E) Conveyor can now be started.

TRACKING CONVEYOR BELT

CAUTION: Before attempting to track conveyor belt, determine that all pulleys and rollers are square with conveyor bed section. Also check bed/frame sections for level and squareness. After completion of these checks and after necessary adjustments have been made to bring sections level and square, follow belt tracking instructions as shown below.

NOTE: On belt driven live roller conveyor, product flow is in opposite direction to belt travel.

- 1) When belt is running toward terminal end "1":

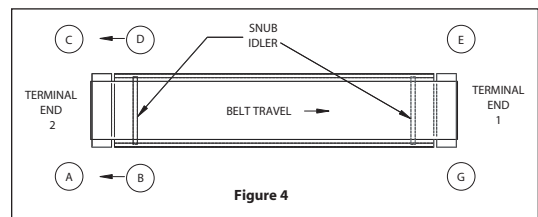

(See Figure "4")

- If belt runs to right side (A) of end pulley, move right side (B) of snub roller toward end pulley.
- If belt runs to the left side (C) of end pulley, move left side (D) of snub roller back towards end pulley.
- If belt runs off right side (G) of end pulley, but is centered on opposite end pulley, move end pulley out slightly on right side (G) using square adjustment.
- If belt runs off left side of end pulley (E), move left side of end pulley (E) out. (Refer to Figure "4" on previous page.)

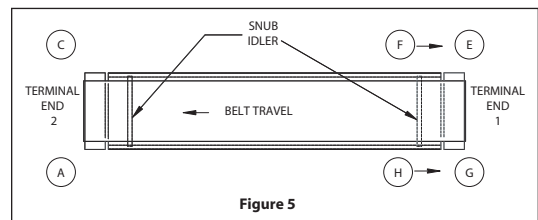

- 1) When belt is running toward terminal end "2": (See Figure "5")

- If belt runs to right side (E) of end pulley, move right side (F) of snub roller toward end pulley.
- If belt runs to the left side (G) of end pulley, move left side (H) of snub roller towards end pulley.
- If belt runs to right side (A) of end pulley, but is centered on opposite end pulley, move left side of end pulley (A) out slightly using adjusting screws provided.

- If belt runs to right side of end pulley (C), but is centered on opposite end pulley, move right side of end pulley (C) out.
- **IMPORTANT NOTE:** When making adjustments on snub and return rollers and pulleys, make adjustments in small increments (1/16" to 1/8") and give belt time to react before adjusting further.

PREVENTATIVE MAINTENANCE

(See Lubrication and Maintenance Check List for more details.)

- 1) **DRIVE CHAINS** - Every 750 hours - Wipe off grease with solvent and apply clean SAE 20 motor oil. Check tension on main drive chain (1/4" - 2% (of sprocket centers) movement mid-way between sprockets). Use straight edge and check sprocket alignment.
- 2) **ELECTRIC MOTOR** - Every 1000 hours - Remove grease plugs (if supplied on motor) and grease motor bearings sparingly with ball bearing grease.
- 3) **SPEED REDUCER** - Every 750 hours - Remove filler and drain plugs. Flush and refill with lubricant suggested by reducer manufacturer.
- 4) **TREAD ROLLERS** - Every 500 Hours - Make sure all rollers turn freely. Replace any that are dented, warped, binding, etc.
- 5) **FLANGE MOUNTED BEARINGS (PULLEYS)** - Every 1000 hours - Grease pulley bearings through grease fittings using grease gun. **CAUTION:** Do not over grease.
- 6) **ENTIRE CONVEYOR** - Daily, weekly. - Look for any abnormal action of conveyor, oil leaks, unusual noises, etc. Repair at once.

ADD END VIEW OF 190RBWS

ADD END VIEW OF 190RB

- PARTS LIST -
190RB-190RBI-190RBWS

